

Glass Passivated Standard Recovery Diodes (Stud Version), 85A

FEATURES

- Glass passivated chips
- High surge current capability
- Stud cathode and stud anode version
- Wide current range
- Voltage up to 1600V V_{RRM}
- RoHS compliant



DO-203AB(DO-5)

TYPICAL APPLICATIONS

- Battery charges
- Converters
- Power supplies
- Machine tool controls
- Welder

PRODUCT SUMMARY

$I_{F(AV)}$	85A
-------------	-----

MAJOR RATINGS AND CHARACTERISTICS

PARAMETER	TEST CONDITIONS	85D(R)		UNIT
		02 TO 12	16	
$I_{F(AV)}$	T_C	85		A
		140	110	°C
$I_{F(RMS)}$		133		A
I_{FSM}	50 HZ	1700		A
	60 HZ	1780		
I^2t	50 HZ	14450		A ² s
	60 HZ	13150		
V_{RRM}	Range	200 to 1200	1600	V
T_J		-65 to 180	-65 to 150	°C

ELECTRICAL SPECIFICATIONS

VOLTAGE RATINGS

TYPE NUMBER	VOLTAGE CODE	$V_{RRM,MAXIMUM}$ REPETITIVE PEAK REVERSE VOLTAGE V	$V_{RSM,MAXIMUM}$ NON-REPETITIVE PEAK VOLTAGE V	$V_{RRM,MAXIMUM}$ TJ-TJ=Maximum mA
85D(R)	02	200	300	9
	04	400	500	
	06	600	700	
	08	800	900	
	10	1000	1100	
	12	1200	1300	
	16	1600	1700	4.5

FORWARD CONDUCTION						
PARAMETER	SYMBOL	TEST CONDITIONS		85D(R)		UNIT
				02 TO 12	16	
Maximum average forward current at case temperature	$I_{F(AV)}$	180° conduction, half sine wave		85		A
				140	110	°C
Maximum RMS forward current	$I_{F(RMS)}$			133		A
Maximum peak, one-cycle forward, non-repetitive surge current	I_{FSM}	t = 10ms	No voltage reappplied	1700		A
		t = 8.3ms	No voltage reappplied	1800		
		t = 10ms	100% V_{RRM} reappplied	1450		
		t = 8.3ms	100% V_{RRM} reappplied	1500		
Maximum I^2t for fusing	I^2t	t = 10ms	No voltage reappplied	14450		A ² s
		t = 8.3ms	No voltage reappplied	13170		
		t = 10ms	100% V_{RRM} reappplied	10230		
		t = 8.3ms	100% V_{RRM} reappplied	9340		
Maximum $I^2\sqrt{t}$ for fusing	$I^2\sqrt{t}$	t = 0.1 to 10 ms, no voltage reappplied		144500		A ² \sqrt{s}
Maximum forward voltage drop	V_{FM}	$I_{pk} = 267A, T_J = 25^\circ C, t_p = 400\mu s$ rectangular wave		1.2	1.4	V

FORWARD CONDUCTION						
PARAMETER	SYMBOL	TEST CONDITIONS		85D(R)		UNIT
				02 TO 12	16	
Maximum junction operating and storage temperature range	T_J			- 65 to 180	- 65 to 150	°C
Maximum thermal resistance, junction to case	R_{thJC}	DC operation		0.35		K/W
Maximum thermal resistance case to heatsink	R_{thCS}	Mounting surface, smooth, flat and greased		0.25		
Maximum allowable mounting torque (+0% , -10%)		Not lubricated thread ,tighting on nut ⁽¹⁾		3.4(30)		N · m (lbf · in)
		Lubricated thread ,tighting on nut ⁽¹⁾		2.3(20)		
		Not lubricated thread ,tighting on hexagon ⁽²⁾		4.2(37)		N · m (lbf · in)
		Lubricated thread ,tighting on hexagon ⁽²⁾		3.2(28)		
Approximate weight				15		g
				0.53		oz.
Case style		See dimensions - link at the end of datasheet		DO-203AB (DO-5)		

Note

- (1) Recommended for pass-through holes.
- (2) Recommended for holed threaded heatsinks.

ΔR_{thJC} CONDUCTION				
CONDUCTION ANGLE	SINUSOIDAL CONDUCTION	RECTANGULAR CONDUCTION	TEST CONDUCTIONS	UNITS
180°	0.10	0.08	$T_J = T_J$ maximum	K/W
120°	0.11	0.11		
90°	0.13	0.13		
60°	0.17	0.17		
30°	0.26	0.26		

Note

- The table above shows the increment of thermal resistance R_{thJC} when devices operate at different conduction angles than DC

Fig.1 Current Ratings Characteristics

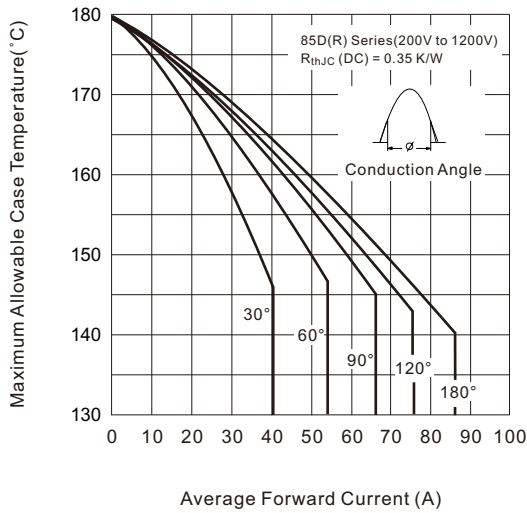

Fig.2 Current Ratings Characteristics

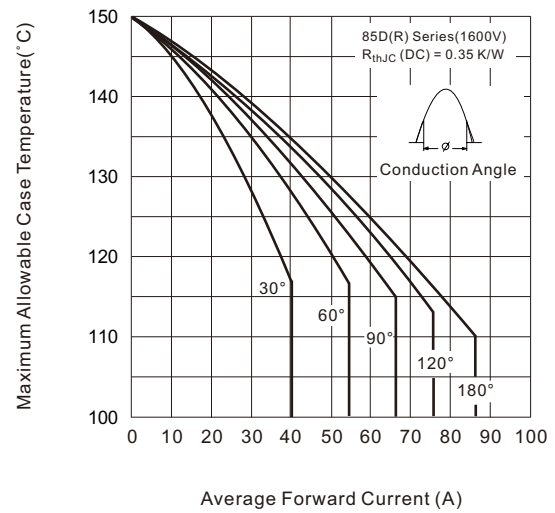

Fig.3 Current Ratings Characteristics

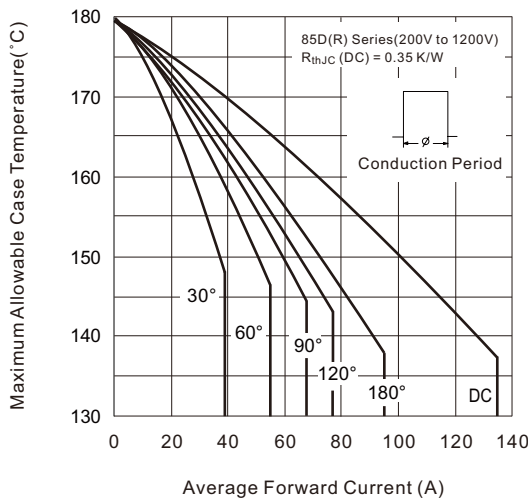

Fig.4 Current Ratings Characteristics

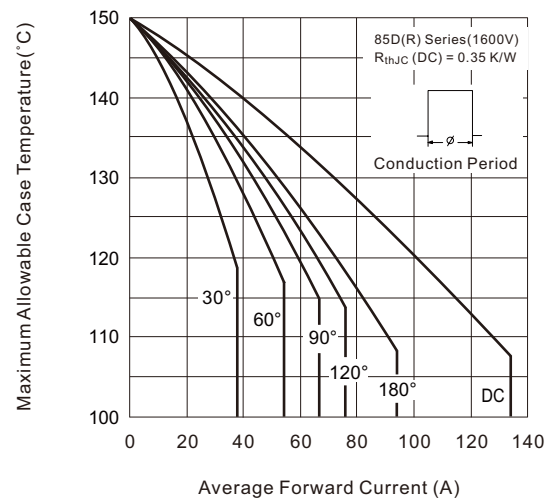

Fig.5 Forward Power Loss Characteristics

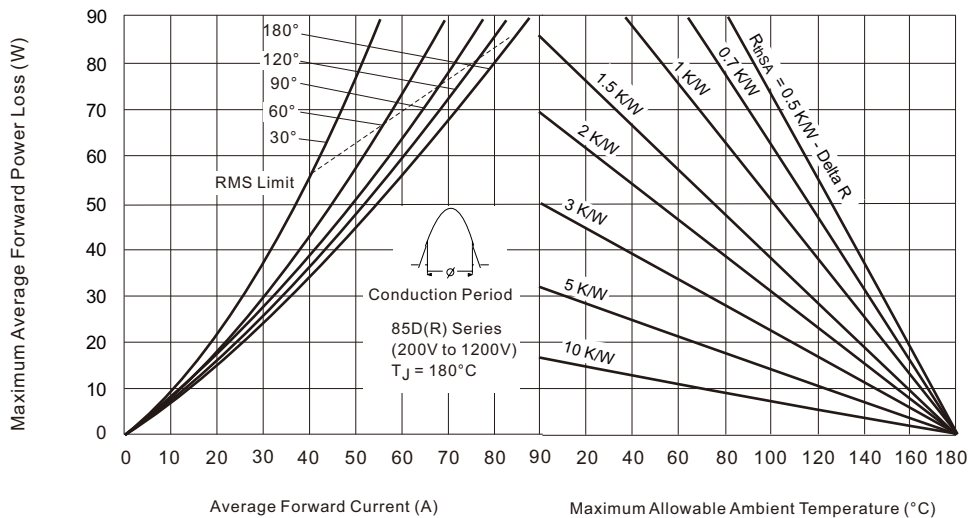

Fig.6 Forward Power Loss Characteristics

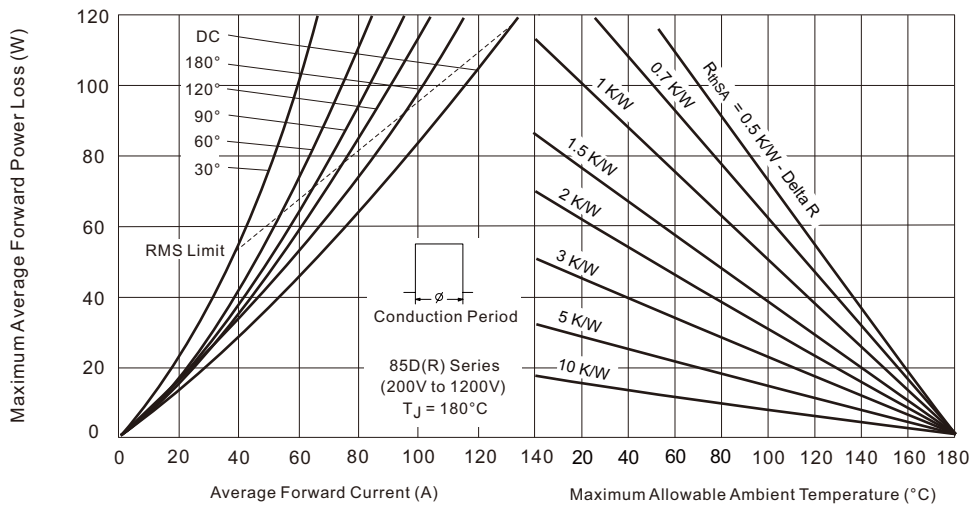

Fig.7 Forward Power Loss Characteristics

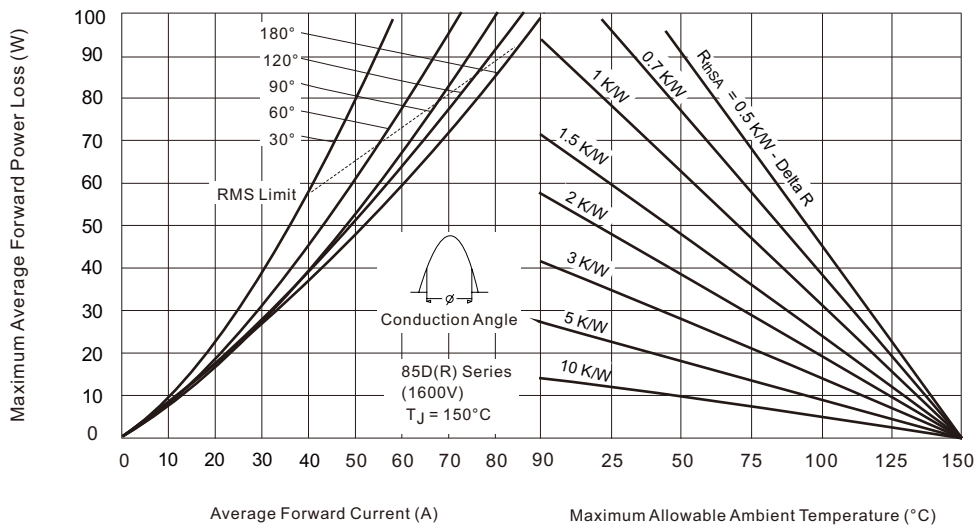

Fig.8 Forward Power Loss Characteristics

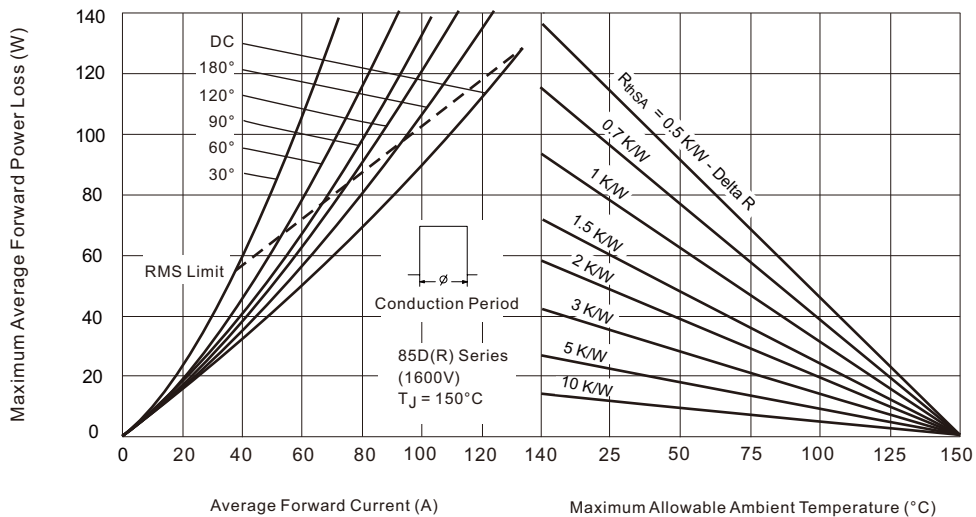

Fig.9 Maximum Non-Repetitive Surge Current

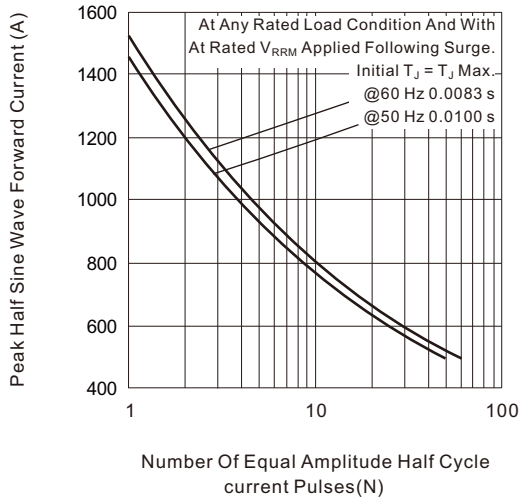

Fig.10 Maximum Non-Repetitive Surge Current

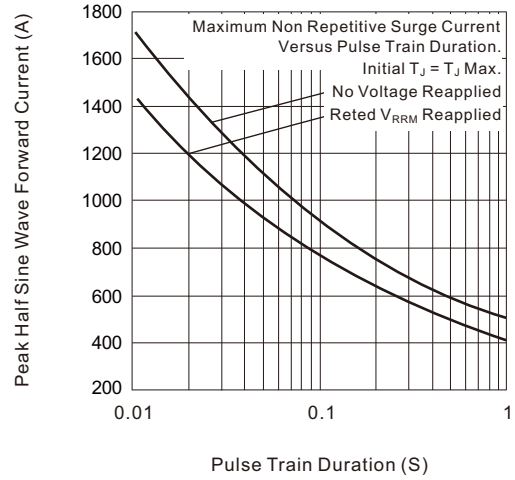

Fig.11 Forward Voltage Drop Characteristics (Up To 1200V)

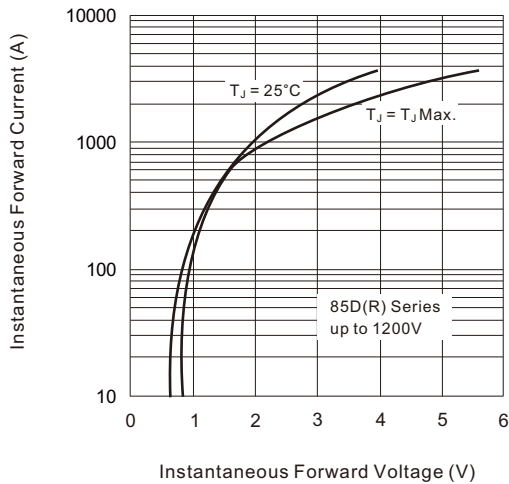

Fig.12 Forward Voltage Drop Characteristics (for 1600V)

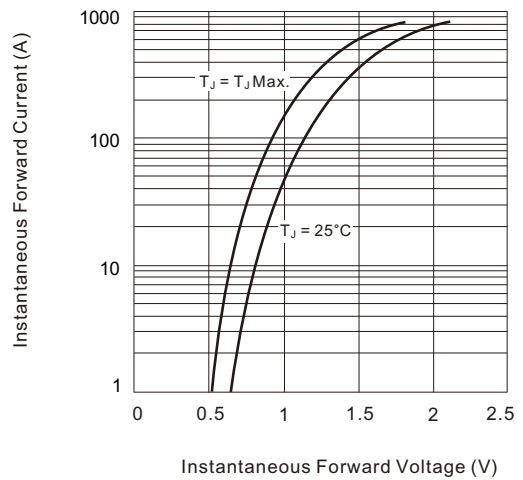
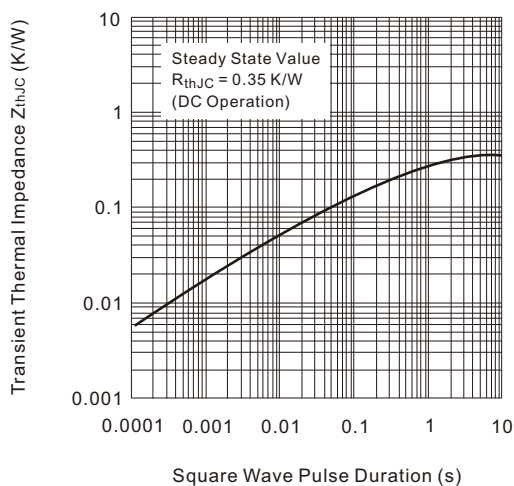

Fig.13 Thermal Impedance Z_{thJC} Characteristics



ORDERING INFORMATION TABLE

Device code	85	D	R	12	M
	①	②	③	④	⑤

- ① - Current rating: Code = $I_{F(AV)}$
- ② - D = Standard recovery device
- ③ - None = Stud normal polarity (cathode to stud)
R = Stud reverse polarity (anode to stud)
- ④ - Voltage code $\times 100 = V_{RRM}$ (see Voltage Ratings table)
- ⑤ - None = Stud base DO-203AB (DO-5) 1/4"-28 UNF-2A, standard type
M = Stud base DO-203AB (DO-5) M6 \times 1.0, standard type
S = Stud base DO-203AB (DO-5) M8 \times 1.0, "Semikron" type

DO-203AB(DO-5), standard type Glass-Metal Seal

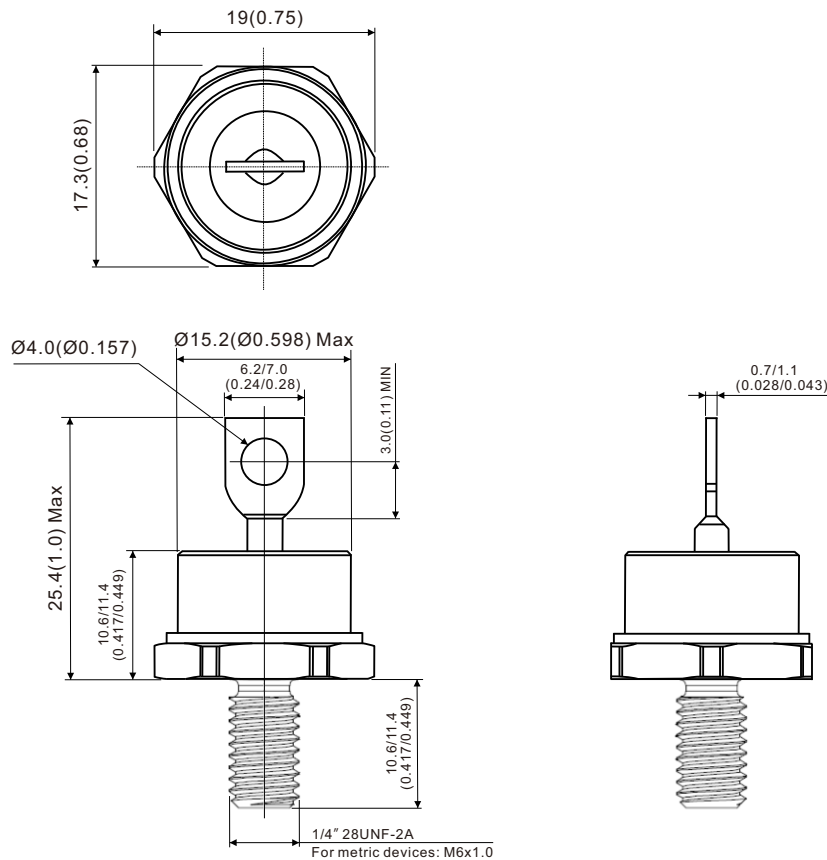

All dimensions in millimeters (inches)

**DO-203AB(DO-5), "Semikron" type
Glass-Metal Seal**

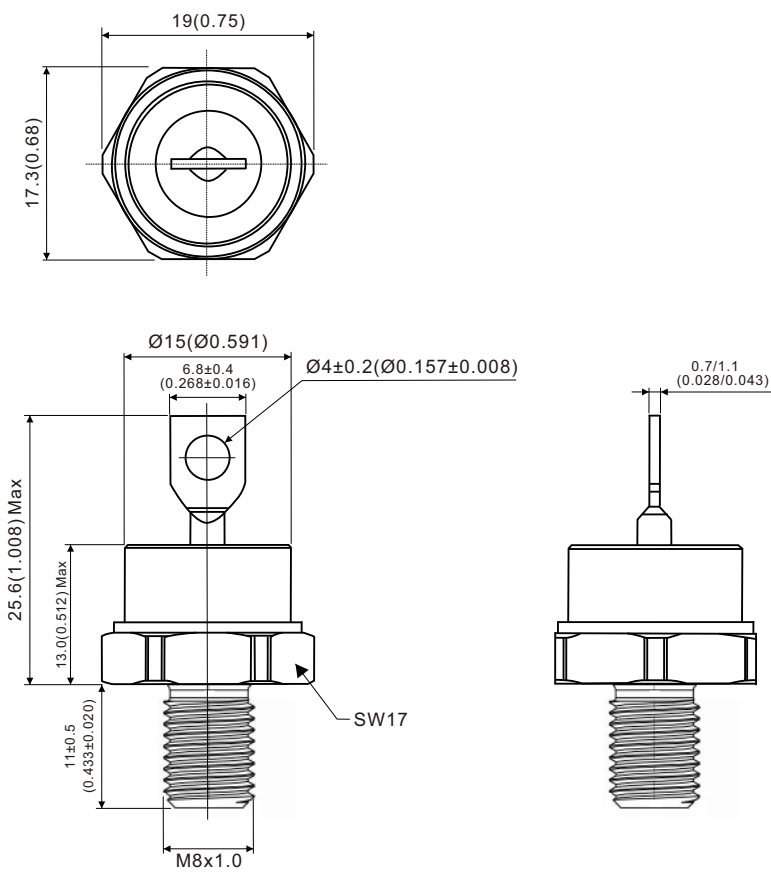

All dimensions in millimeters (inches)